

Product Name: **BOV Kompact EM F150**  
 Product Description: BOV Kompact EM F150  
 Product Number: TS-0225-1001  
 Document Version: V1.00 Rev A



**IMPORTANT NOTES ON YOUR BOV**

- Turbosmart accepts no responsibility whatsoever for incorrect installation of this product which is potentially hazardous and can cause serious engine damage or personal injury.
- The EM series BOV is designed for use as a factory replacement for a turbocharger that utilises an electronic diverter valve, this valve can be used on other applications as long as there is a control signal to actuate the BOV.
- Ensure the engine is cold prior to installation.

**RECOMMENDATIONS**

- **Turbosmart recommends that your Blow off valve (BOV) is fitted by an appropriately qualified technician**



**KIT CONTENTS**

Please check that the following items have been provided in your EM Series BOV packaging

Part	Description	Use
1	Turbosmart EM Series BOV	Main unit
1	Mounting Brackets	Mounting BOV to intercooler x 2 Model dependent
1	Plumb back block off	Block off OEM plumb back hose
4	Turbosmart Sticker	Turbosmart sticker

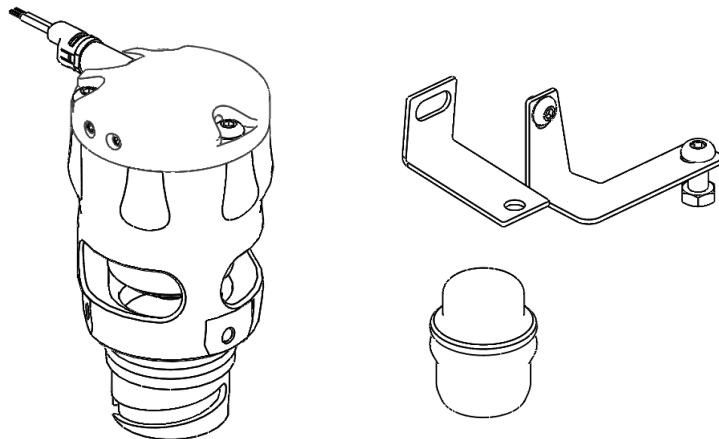

**Figure 1 - Kit Contents**

---

## ABOUT YOUR EM SERIES BOV

Turbosmart has developed a unique “plug and play” diverter valve (or bypass valve) upgrade for your vehicle that is currently equipped with an electronic diverter valve. While we have developed this unit to be as simple as possible for you to install, we have not compromised on performance. This unit will not leak under elevated boost pressures and will still provide you with rapid response ensuring that all the OEM calibration strategies are not interfered with, providing you with maximum boost performance while the advanced strategies of the OEM's are retained.

The EM series BOV is available in two configurations, Dual Port and Plumb Back. The functionality of the BOV is still the same, there is no performance difference between the two units, it is a personal preference if the user wishes to utilise a classic vent to atmosphere sound or revert all bypass gasses back into the inlet tract of the turbocharger.

As the valve is completely controlled by the factory engine control unit, the factory diverter valve is almost silent, due to our construction, it is possible that your EM series will be much more audible. By being able to hear the unit actuate, occasionally the valve may be opening for a few seconds under the following events such as traction control, cruise control management, rapid gearchanges and varying throttle position changes, these are all coded as part of the torque management software in the OEM engine control unit, there is no adjustment available over these functions via our product. By hearing these events, it is not abnormal, it is completely normal for the EM series BOV to be considered “very active” as it is protecting your turbocharger from surge events or bypassing air for torque management purposes.

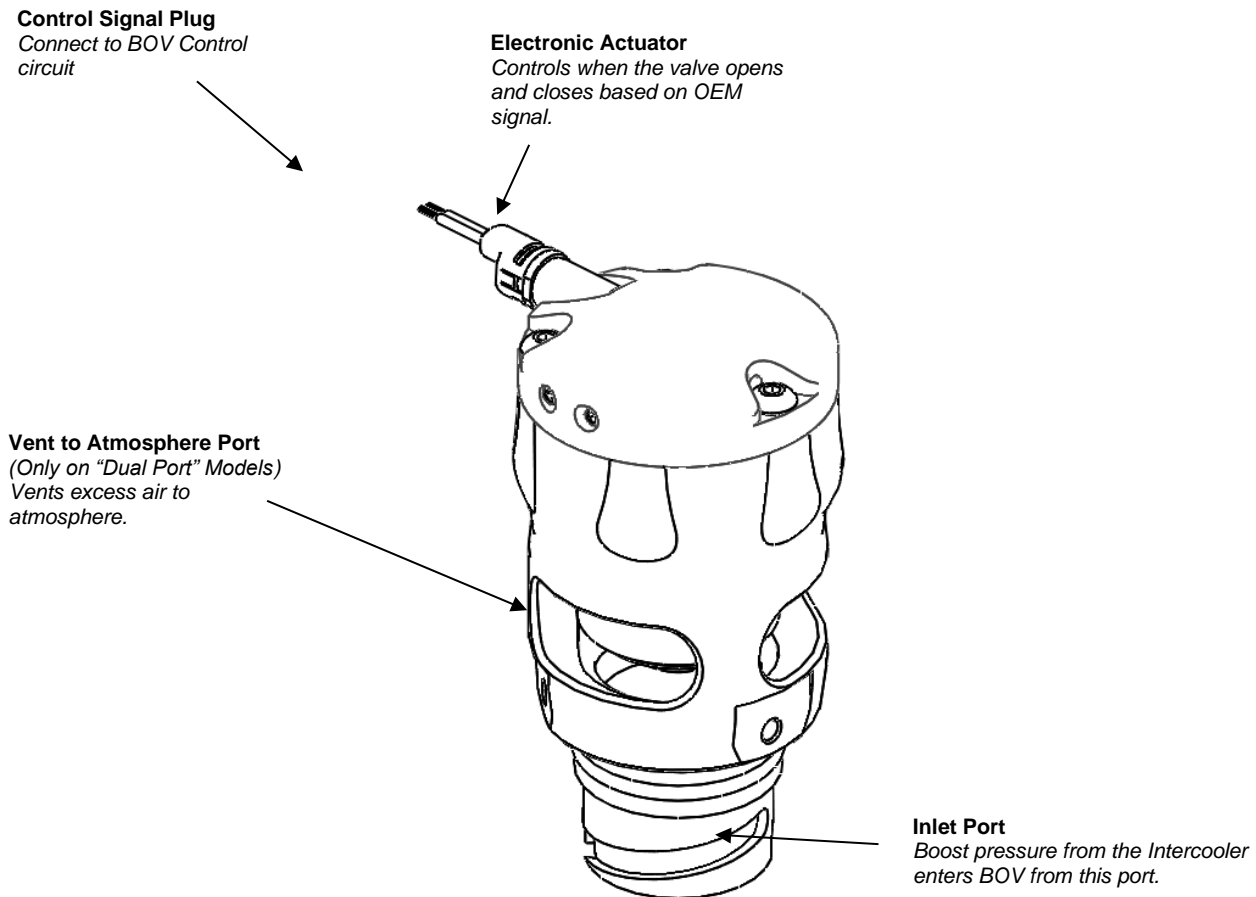

Figure 2 - EM Series BOV Overview

## FITTING YOUR EM SERIES BOV

1

### Identify Diverter Valve Location



On the 13<sup>th</sup> Generation Ford F Series Truck (P552) the diverter valve is located on the intercooler on the twin turbo model. This is located at the front of the car in the lower grill portion. It is accessible from the bottom of the car.

2

### Removing the Undertray

Remove the under-tray of the vehicle by removing all the plastic clips holding the tray in place. Once the under-tray is removed, the intercooler assembly can be accessed. Unplug the OEM BOV plug. It will be held to the car with electrical tape. The intercooler piping will also need to be removed. Undo the bolts securing the cross member to remove the intercooler from the vehicle.



3

### Removing BOV Chamber from Plumb back Hose

Unplug the BOV chamber from the OEM plumb back hose. Install the supplied plumb back hose blanking plug by pressing it into the plumb back hose plug. Please note that the blanking plug will only fit the plumb back hose in one way.



3

### Remove the Diverter Valve from Intercooler.

Once the intercooler assembly is removed from the vehicle, the OEM BOV can be upgraded. Remove the OEM BOV by undoing the two bolts holding it onto the BOV chamber. Some models will have a mount on the canister as well.



#### 4 Removing BOV chamber from Intercooler

Remove the BOV chamber by turning it upwards. The BOV chamber should just unscrew.

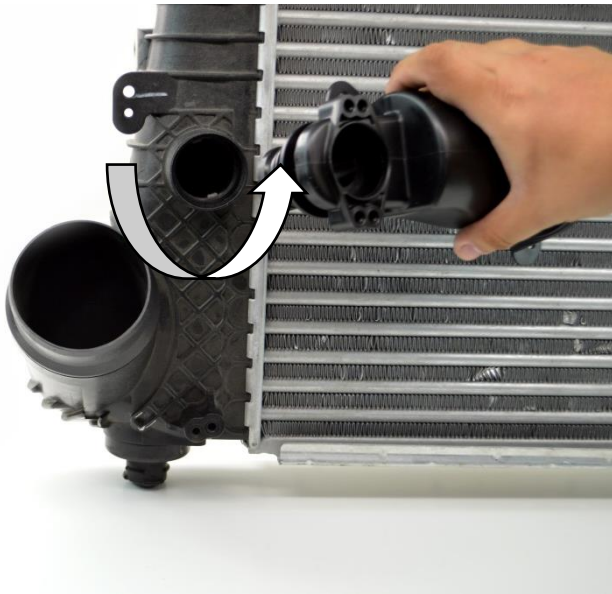

#### 4 Securing BOV Mount to BOV.

Secure the Bracket onto the side of you F150 EM BOV using supplied M5 screw, Screw the BOV into the intercooler.

#### CAUTION!

Do NOT use the solenoid as leverage to screw the EM BOV in as this may cause permanent damage.

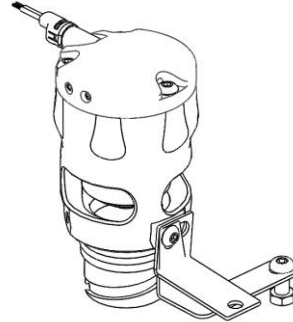

#### 4 Reinstalling Intercooler.

Reinstall Intercooler into the vehicle and connect the plug on the EM Solenoid into the factory BOV control plug. Ensuring to hear a click of the connector locking together.

#### 4 Install the under tray.

Reinstall undertray, start your vehicle and enjoy your new Turbosmart BOV

## CHANGING THE ELECTRONIC ACTUATOR

#### 1 Remove Your EM series BOV

Remove the electronic plug from the EM series BOV and remove the BOV from the vehicles

#### NOTE!

Cosmetic engine covers may be required to be removed prior to the assembly being visible.

#### CAUTION!

The turbocharger assembly may require the vehicle to be raised on a hoist or jacked up and secured using vehicle jack stands, ensure your safety is not compromised.

#### 2 Remove Electronic Actuator from your EM series BOV

Using a 11mm open end wrench in the flat sides of the solenoid, undo the actuator in an anti-clockwise direction when viewed from the end. Ensure the wrench is placed on the metallic portion of the flats and not on the plastic cover.

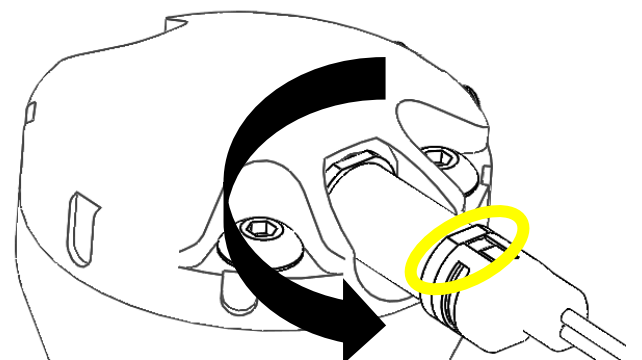

Ensure the cavity is free from debris using avoiding shifting dirt into the passages.

#### 3 Install New Electronic Actuator into your EM series BOV

Ensure the O-rings on your new actuator are correctly seated in the grooves before installation

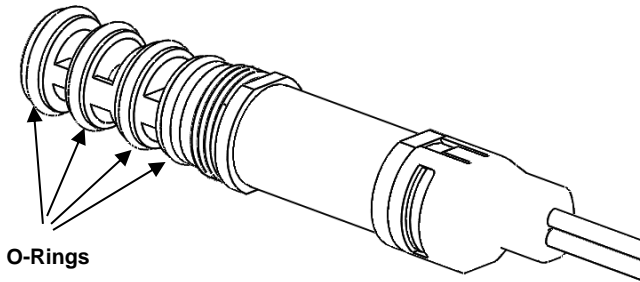

**CAUTION!**

Failure to ensure O-rings are seated correctly may lead to cutting of an O-Ring and unexpected results from the EM series BOV

Slowly insert the new actuator while turning in a clockwise direction to avoid tearing the O-rings

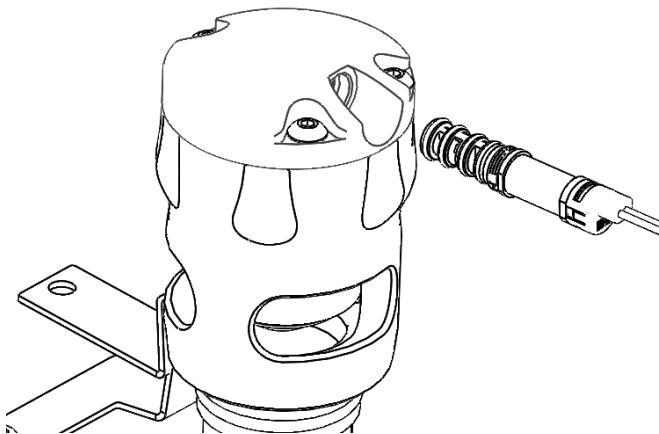

Tighten the new solenoid into the EM series BOV ensuring the wrench is on the metallic portion of the solenoid.

**NOTE!**

Tightening the solenoid on the plastic cover may result in unreparable damage to the solenoid.

**4 Mount your EM Series BOV**

Reinstall the BOV

Once the valve has been mounted, connect the electrical plug into the OEM factory plug or into BOV controller and secure the wiring safely away from a heat source.

Congratulations, your EM Series BOV is installed and ready for use. Double check all electrical connections and mounting screws.

**TROUBLE SHOOTING**

- BOV not actuating - Confirm electrical signal plug is connected appropriately, as the plugs are new, some force may be required to click the plug into place.
- Valve is staying open – Confirm the valve has O-rings as they may have been dropped or lost during installation
- Boost pressure loss or lower than before - Confirm the valve has O-rings as they may have been dropped or lost during installation
- Failing the above, submit a technical request to [tech@turbosmart.com.au](mailto:tech@turbosmart.com.au) with information of your engine configuration and photos of installation