

# Gen V WG45 Hypergate45 Lite



The Gen-V WG45 Hypergate45 Lite external wastegate is a cost effective, high performing 45mm external wastegate. The Gen-V provides extensive user configurability, world leading extended thermal performance, fatigue resistance and best in class flow performance for optimum control and longevity.

- Liquid cooling provision
- Strap type V-band clamps
- User adjustable actuator position
- Modular actuator design
- Motorsport Endurance / Compressed Gas options available

### Mechanical Data

Valve diameter	45mm (1.77in)
Mass	878g (1.94lbs)
Actuator linearity	1.02% of full lift (BFSL)
Set pressure accuracy	+/- 0.5 psi of base pressure
Safe working pressure max.	220 psi / 1520 kPa / 15 bar
Safe inverted pressure max.	180 psi / 1250 kPa / 12.5 bar
Actuator life	550k cycles @ 180°C (356 °F) ambient 800k cycles @ 80°C (176 °F) ambient
Actuator/Valve ratio	1.5:1
Max. spring base pressure	26 psi / 180 kPa / 1.8 bar
Min. spring base pressure	3 psi / 21 kPa / 0.2 bar
Port fittings type	Air: 2x 1/8" NPT top chamber Air: 2x 1/8" NPT lower chamber Liquid Cooling: 2x 1/8" NPT

### Thermal Data

Max. thermal stress (non-cooled)*	>45min @ 1250°C (2282°F) EGT continuous
Max. thermal stress (h2O cooled)*	>24hr @ 1250°C (2282°F) EGT continuous
Max. ambient/compartament temp.	260°C / 500°F
Max. actuator temp.	310°C / 590°F

### Material Data

Beryllium (Be)	0%
Main Body	High temp 347 SS
Diaphragm	Proprietary Silicone w/ nomex
Actuator housing	6061 T6 anodised Al.
Valve Guide	Nitronic 60
Valve	EV8 w/ proprietary plating
V-Band	Heat treated 431 SS w/ 18-8 nut
Weld Flanges	304 Stainless Steel
Springs	17-7PH Stainless Steel

### Flow Data

Max. Flow	209.9 CFM/5.94m <sup>3</sup> /min @1psidP
Flow Linearity	-18% of full lift (BFSL)

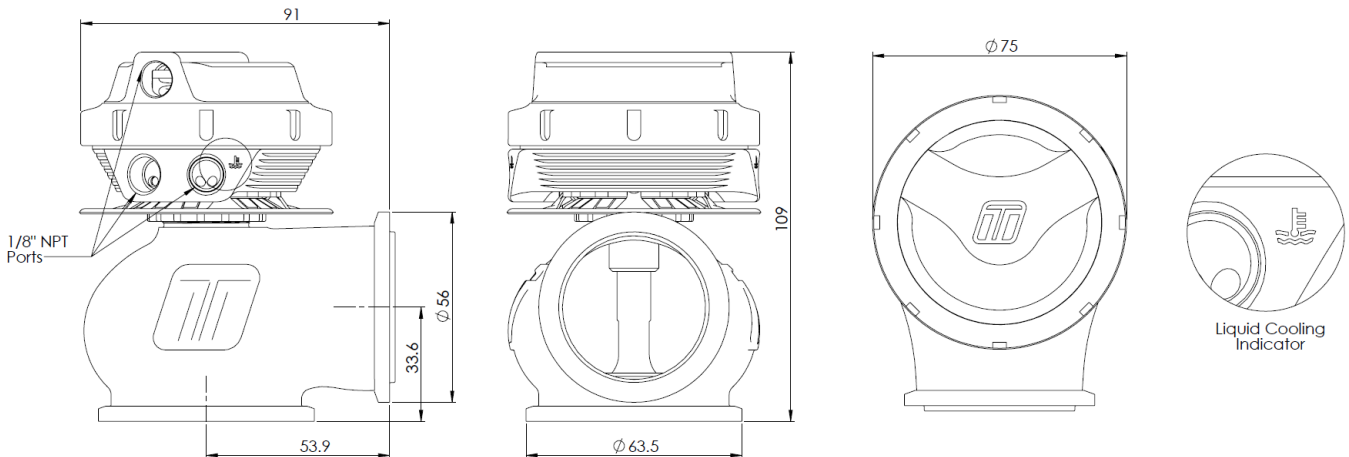
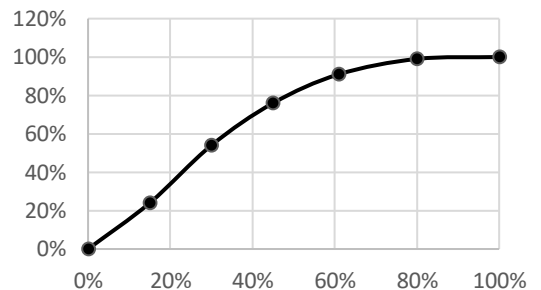

\*Continual source of minimum 1250°C exhaust gas, with no cool down periods for at least 30minutes and no external air cooling on actuator, this is a destructive test that an ICE engine cannot support. Contact tech support for further information.

**Included in the Box**

- Wastegate unit (pre-assembled with spring as per order)
- SS316 Valve seat
- Inlet V-Band
- Inlet SS304 weld flange
- Outlet V-Band
- Outlet SS304 weld flange
- Collar tool (master/slave)
- 817-7PH 3, 5, 7, 14 psi spring kit (1x spring installed)
- 4x 1/8" NPT plugs (1x installed) / 2x 1/8" NPT nipples
- Sticker
- Instruction card

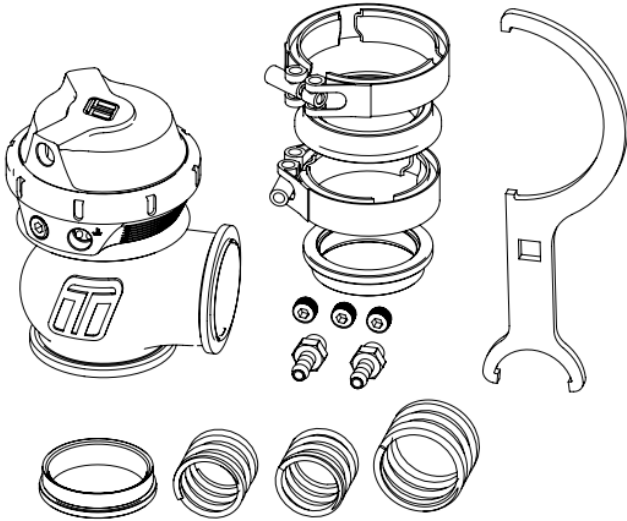

**Spring Data**

Master Collar Size	Spring Pressure			
	3psi	5psi	7psi	14psi
74mm	Black	Grey	Pink	Red

**Order Data**

- TS-0553-1602 Gen-V WG45 Hypergate 45 Lite 7psi Black
- TS-0553-1612 Gen-V WG45 Hypergate 45 Lite 14psi Black
- TS-0553-1615 Gen-V WG45 Hypergate 45 Lite 14psi Black Sleeper

**Accessories**

- TS-0553-3001 WG45 Valve seat
- TS-0553-3002 WG45 Valve and Guide set
- TS-0553-3003 WG45 Inlet V-Band
- TS-0553-3004 WG45 Outlet V-Band
- TS-0504-3007 WG45 Alloy Inlet Weld Flange
- TS-0504-3008 WG45 Alloy Outlet Weld Flange
- TS-0550-3001 74mm Spring Kit
- TS-0550-3022 74mm Sensor Cap Upgrade Black
- TS-0550-3023 74mm Sensor Cap Upgrade Blue
- TS-0550-3004 74mm Diaphragm Replacement Kit
- TS-0550-3013 74mm Actuator Collar Tool

*Refer to catalogue for further accessories*

**Install Req.**

- Inlet Pipe Suits 47.63mm/1.875" OD
- Outlet Pipe Suits 44.45mm/1.75" OD
- Port Tube Min. ID 6mm / 0.236"

Boost Pressure	Location	Inner	Inner	Middle	Outer
	Pressure	3psi	5psi	7psi	14psi
3psi		•			
5psi			•		
7psi				•	
10psi		•		•	
12psi			•	•	
14psi					•
17psi		•			•
19psi			•		•
21psi				•	•
24psi		•		•	•
26psi			•	•	•