

Gen V eWG45 Hypergate45



The Gen-V WG45 Hypergate45 external electronic wastegate is a cost effective, high performing 45mm external wastegate. The Gen-V provides extensive user configurability, world leading extended thermal performance, fatigue resistance and best in class flow performance for optimum control and longevity.

- Liquid cooling provision
- Strap type V-band clamps
- User adjustable actuator position
- Modular actuator design
- Full Electronic control

Mechanical Data

Valve diameter	45mm (1.77in)
Mass	WG45 1846g (4.069lbs)
Actuator linearity	1.02% of full lift (BFSL)
Set pressure accuracy	+/- 0.5 psi of base pressure
Safe working pressure max.	220 psi / 1520 kPa / 15 bar
Safe inverted pressure max.	180 psi / 1250 kPa / 12.5 bar
Actuator life	550k cycles @ 150°C (302 °F) ambient 800k cycles @ 80°C (176 °F) ambient Liquid Cooling: 2x 1/8" NPT
Port fittings type	

Thermal Data

Max. thermal stress (non-cooled)*	>45min @ 1250°C(2282 °F) EGT continuous
Max. thermal stress (h2O cooled)*	>24hr @ 1250°C(2282°F) EGT continuous
Max. ambient/compartament temp.	260°C / 500°F
Max. actuator temp.	150°C / 257°F

Electrical Data

Sensor Operating voltage	5V±0.5V
Outputs	<ul style="list-style-type: none"> • Analog 0-5V • Pulse Width Modulated signal -40 °C to 150 °C(-40 °F to 302 °F)
Operating Temperature	
Sensor Supply Current	21mA
PWM Frequency	220-268 Hz

Temp Sensor Data

Accuracy	±2.7°C	
Voltage offset at 0°C	2630mV	
Gain	-13.6mV/°C	
Deg C (Deg F)	Rev A Temp Sensor Output (mV)	Rev B Temp Sensor Output (mV)
0 °C (32 °F)	500	2630
150 °C (302 °F)	2000	538

Position Sensor Data

Position	Target Voltage (V)	Duty Cycle (Rev B)
100%	0.20-0.60V	~16%
0%	4.40-4.80V	~84%

Connection Data

Red 22AWG	5V
Black 22AWG	0V
White 22AWG	Valve position
Blue 22AWG (Rev B Only)	*Unfiltered Signal (Position Output)
Yellow 22AWG (Orange Rev A)	Sensor Temperature
Red 14AWG	Motor A (positive closed)
Black 14AWG	Motor B (positive open)

*Note: The Blue (unfiltered position signal) is not required for use & is for development purposes only.

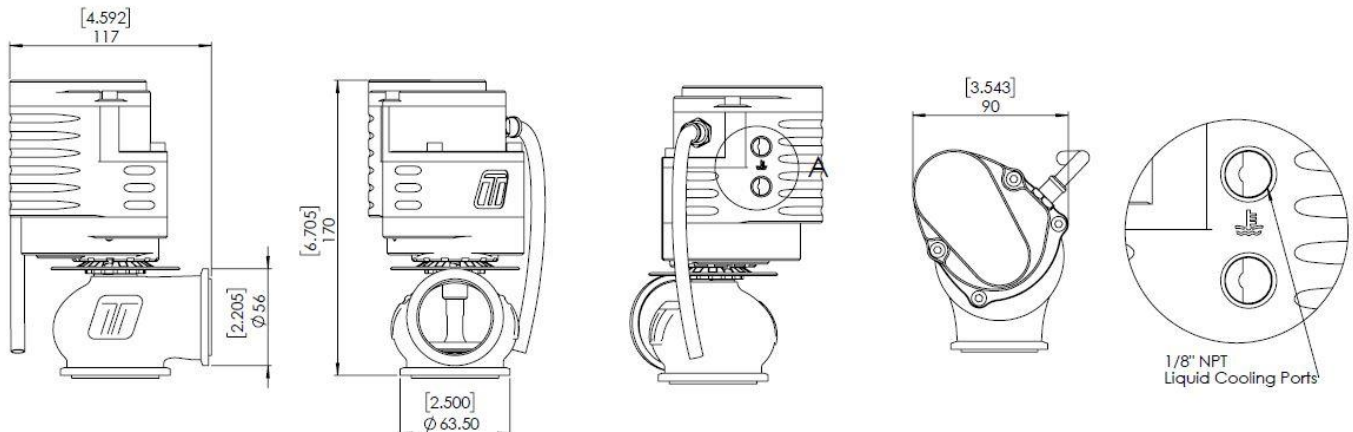

*Continual source of minimum 1250°C exhaust gas, with no cool down periods for at least 30minutes and no external air cooling on actuator, this is a destructive test that an ICE engine cannot support. Contact tech support for further information.

Material Data

Beryllium (Be)	0%
Main Body	High temp 347 SS
Actuator housing	6061 T6 anodised Al.
Valve Guide	Nitronic 60
Valve	EV8 w/ proprietary plating
V-Band	Heat treated 431 SS w/ 18-8 nut
Weld Flanges	304 Stainless Steel

Motor Data

Wire Size	14AWG
Direction	Red wire positive closed
Stall Current**	60A
Hold Current	0A (Motor braking available)
Max Force @stall	4085N (918lbf)
Max Force @power	2042N (459lbf)
Speed (Opening)	598%/s

Speed Vs Force

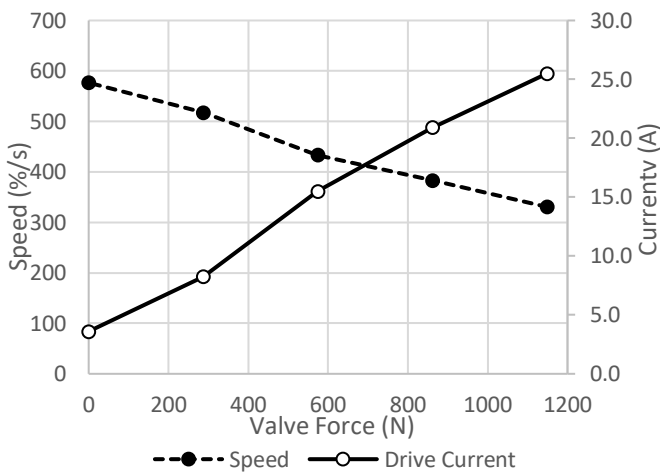

Flow Characteristics

Max. Flow 193.6 CFM/5.48m³/min @1psidP

Flow Linearity -18% of full lift (BFSL)

Flow Linearity

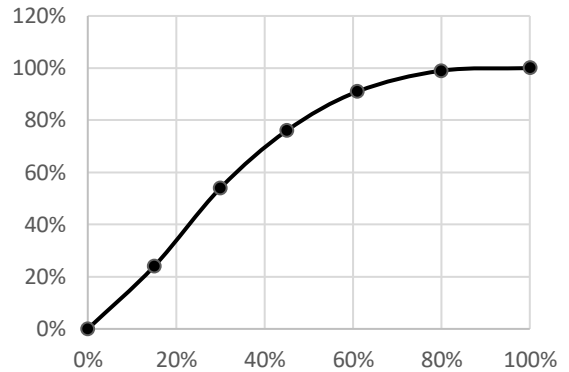

Valve Force Vs Exhaust Pressure

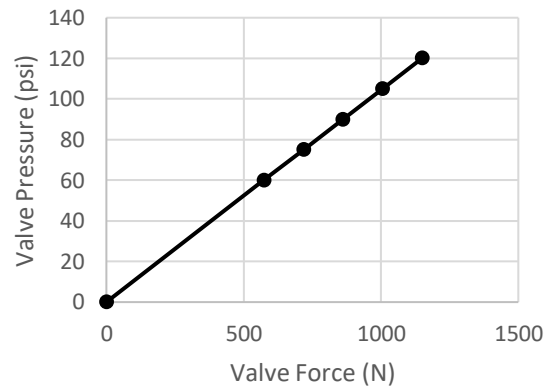

Included in the Box

- Wastegate unit
- SS316 Valve seat
- Inlet V-Band
- Inlet SS304 weld flange
- Outlet V-Band
- Outlet SS304 weld flange
- Collar tool (master/slave)
- Sticker
- Instruction card

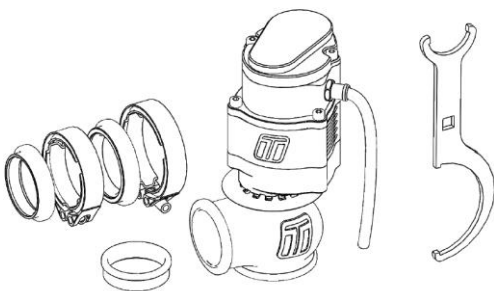

Order Data

TS-0553-1502 Gen-V eWG45 Hypergate 45 Electronic Black

Accessories

- TS-0553-3001 WG45 Valve seat
- TS-0553-3002 WG45 Valve and Guide set
- TS-0553-3003 WG45 Inlet V-Band
- TS-0553-3004 WG45 Outlet V-Band
- TS-0504-3007 WG45 Alloy Inlet Weld Flange
- TS-0504-3008 WG45 Alloy Outlet Weld Flange
- TS-0550-3013 54mm Actuator Collar Tool

Refer to catalogue for further accessories

Install Req.

- Inlet Pipe Suits 47.63mm/1.875" OD
- Outlet Pipe Suits 44.45mm/1.75" OD
- Water Port 6mm / 0.236" (Recommended -4 AN Fitting) Tube Min. ID

** High amperage for prolonged periods will damage the motor, keep high Amperage operation to short bursts.