

Gas Valve Actuator 45mm

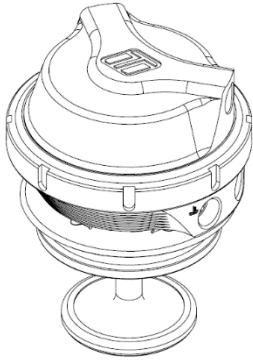

The Gas Valve Actuator 45 (GVA45) is a cost effective, high performing 45mm hot gas actuator valve. Based on Turbosmart's industry leading Gen-V external wastegate technology the GVA provides extensive user configurability, world leading extended thermal performance, fatigue resistance and best in class flow performance for optimum control and longevity.

- Liquid cooling provision
- Strap type V-band clamp
- User adjustable actuator position
- Modular actuator design

Mechanical Data

Valve diameter	45mm (1.77in)
Mass	1006g (2.22lb)
Actuator linearity	1.02% of full lift (BFSL)
Set pressure accuracy	+/- 0.5 psi of base pressure
Safe working pressure max.	220 psi / 1520 kPa / 15 bar
Safe inverted pressure max.	180 psi / 1250 kPa / 12.5 bar
Actuator life	550k cycles @ 180°C (356°F) ambient 800k cycles @ 80°C (176 °F) ambient
Actuator/Valve ratio	2.07:1
Max. spring base pressure	26 psi / 180 kPa / 1.8 bar
Min. spring base pressure	3 psi / 21 kPa / 0.2 bar
Port fittings type	Air: 2x 1/8" NPT top chamber Air: 2x 1/8" NPT lower chamber Liquid Cooling: 2x 1/8" NPT

Thermal Data

Max. thermal stress (non-cooled)*	>30min @ 1250°C (2282°F) EGT continuous
Max. thermal stress (h2O cooled)*	>24hr @ 1250°C (2282°F) EGT continuous
Max. ambient/compartments temp.	260°C / 500°F
Max. actuator temp.	310°C / 590°F

Material Data

Beryllium (Be)	0%
Main Body	High temp 347 SS
Diaphragm	Proprietary Silicone w/ nomex
Actuator housing	6061 T6 anodised Al.
Valve Guide	Nitronic 60
Valve	EV8 w/ proprietary plating
V-Band	Heat treated 431 SS w/ 18-8 nut
Springs	17-7PH Stainless Steel

Flow Data*

Max. Flow	193.6 CFM/5.48m ³ /min @1psidP
Flow Linearity	-18% of full lift (BFSL)

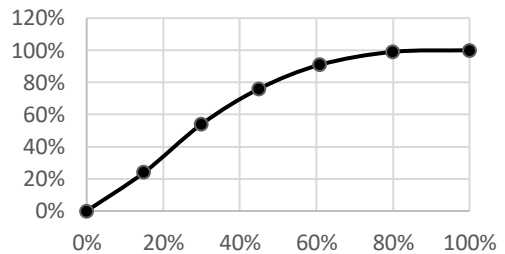

*Flow will be limited by machined geometry of cavity

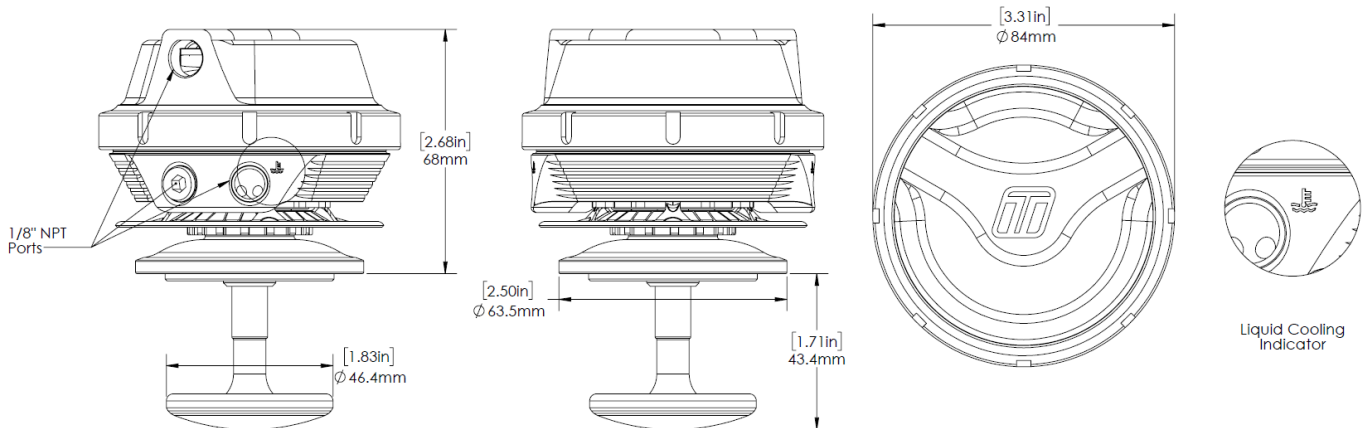

*Continual source of minimum 1250°C exhaust gas, with no cool down periods for at least 30minutes and no external air cooling on actuator, this is a destructive test that an ICE engine cannot support. Contact tech support for further information.

Included in the Box

- Valve actuator unit (pre-assembled with 14psi spring)
- Inlet V-Band
- Collar tool (Optional)
- 4x 1/8" NPT plugs (1x installed) / 2x 1/8" NPT nipples
- Sticker
- Instruction card

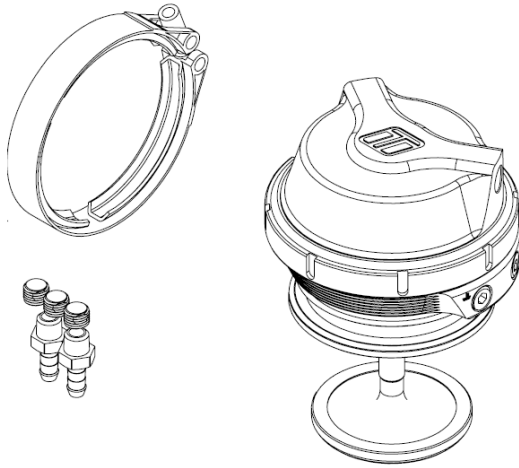

Order Data

TS-0553-1712 GVA45 14psi Black

Accessories

- TS-0553-3002 WG45 Valve and Guide set
 - TS-0553-3003 WG45 Inlet V-Band
 - TS-0550-3151 84mm Spring Kit
 - TS-0550-3024 84mm Sensor Cap Upgrade Black
 - TS-0550-3025 84mm Sensor Cap Upgrade Blue
 - TS-0550-3005 84mm Diaphragm Replacement Kit
 - TS-0550-3014 84mm Actuator Collar Tool
- Refer to catalogue for further accessories*

Spring Data

Master Collar Size	Spring Pressure			
	3psi	5psi	7psi	14psi
84mm	Orange	Yellow	Green	Sky Blue

Boost Pressure	Location	Inner	Inner	Middle	Outer
	Pressure	3psi	5psi	7psi	14psi
3psi		•			
5psi			•		
7psi				•	
10psi		•		•	
12psi			•	•	
14psi					•
17psi		•			•
19psi			•		•
21psi				•	•
24psi		•		•	•
26psi			•	•	•

Basic Cavity Geometry

