

Gen V ProGate 50 CG/ CO2 HP Full Range



The Gen-V WG50CG ProGate50 Compressed Gas external wastegate is a cost effective, high performing 50mm external wastegate designed for control strategies that actively bias the top chamber with high pressure for large boost bandwidth operation, such as CO2 drag racing, or compressed air WRC applications. The Compressed Gas range feature an inverted diaphragm to maximise diaphragm life from high pressure CO2 or compressed air systems. The Gen-V provides extensive user configurability, world leading extended thermal performance, fatigue resistance and best in class flow performance for optimum control and longevity.

- Liquid cooling provision
- Strap type V-band clamps
- User adjustable actuator position
- Modular actuator design
- Standard option available
- Inverted diaphragm for top chamber high pressure support

Mechanical Data

Valve diameter	50mm (1.97in)
Mass	1022g (2.25lbs)
Actuator linearity	1.02% of full lift (BFSL)
Set pressure accuracy	+/- 0.5 psi of base pressure
Safe working pressure max.	220 psi / 1520 kPa / 15 bar
Safe inverted pressure max.	180 psi / 1250 kPa / 12.5 bar
Actuator life	500k cycles @ 180°C (356°F) ambient 650k cycles @ 80°C (176°F) ambient
Actuator/Valve ratio	1.6:1
Max. spring base pressure	26 psi / 180 kPa / 1.8 bar
Min. spring base pressure	3 psi / 21 kPa / 0.2 bar
Port fittings type	Air: 2x 1/8" NPT top chamber Air: 2x 1/8" NPT lower chamber Liquid Cooling: 2x 1/8" NPT

Thermal Data

Max. thermal stress (non-cooled)*	>60min @ 1250°C (2282°F) EGT continuous >24hr @ 1250°C (2282°F) EGT continuous
Max. thermal stress (h2O cooled)*	continuous
Max. ambient/compartament temp.	260°C / 500°F

Material Data

Beryllium (Be)	0%
Main Body	High temp 347 SS
Diaphragm	Proprietary Silicone w/ nomex
Actuator housing	6061 T6 anodised Al.
Valve Guide	Nitronic 60
Valve	EV8 w/ proprietary plating
V-Band	Heat treated 431 SS w/ 18-8 nut
Weld Flanges	304 Stainless Steel
Springs	17-7PH Stainless Steel

Flow Data

Max. Flow	241.6 CFM/6.81m ³ /min @1psidP
Flow Linearity	-17% of full lift (BFSL)

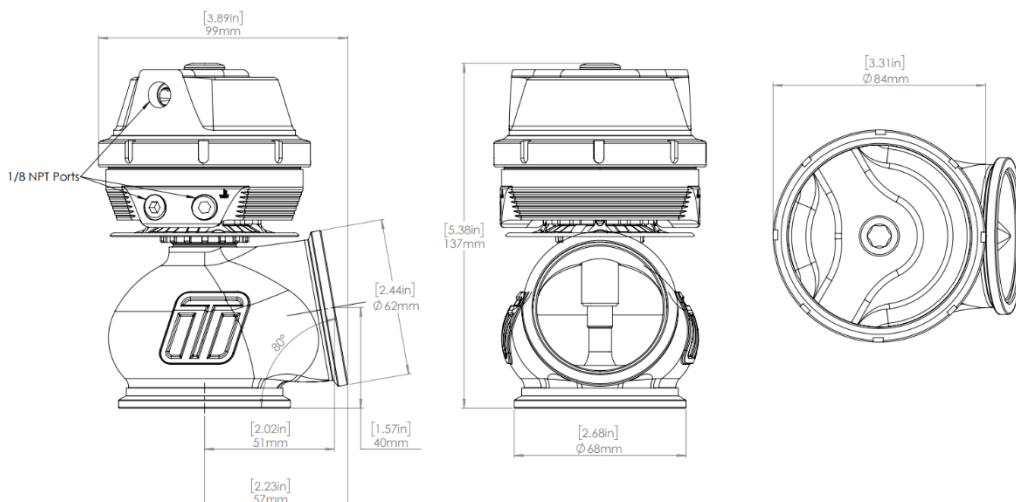
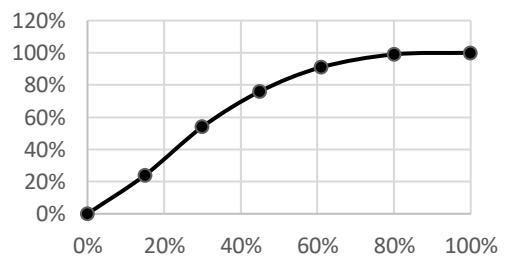

*Continual source of minimum 1250°C exhaust gas, with no cool down periods for at least 30minutes and no external air cooling on actuator, this is a destructive test that an ICE engine cannot support. Contact tech support for further information.

Max. actuator temp.

310°C / 590°F

Included in the Box

- Wastegate unit (pre-assembled with spring as per order)
- SS316 Valve seat
- Inlet V-Band
- Inlet SS304 weld flange
- Outlet V-Band
- Outlet SS304 weld flange
- Collar tool (master/slave)
- 17-7PH 3, 5, 7, 14 psi spring kit (1x spring installed)
- 4x 1/8" NPT plugs (1x installed) / 2x 1/8" NPT nipples
- Sticker
- Instruction card

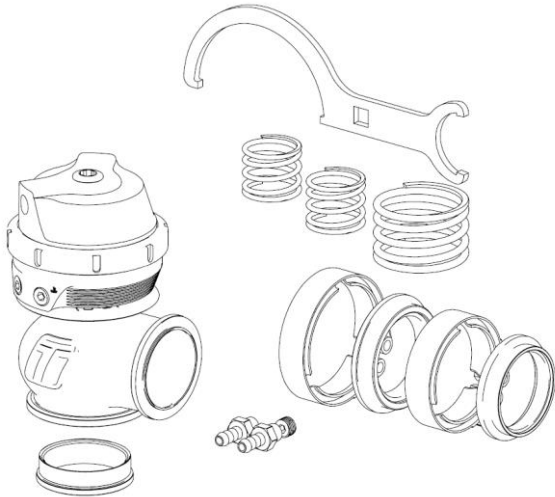

Order Data

TS-0553-1242 GenV CompGate45 CG/CO2 HP Full Range

Accessories

- TS-0554-3001 WG50 Valve seat
- TS-0554-3002 WG50 Valve and Guide set
- TS-0554-3003 WG50 Inlet V-Band
- TS-0554-3003 WG50 Outlet V-Band
- TS-0502-3001 WG50 Stainless Inlet Weld Flange
- TS-0502-3004 WG50 Stainless Outlet Weld Flange
- TS-0550-3085 Gen V (3Psi) Inner (Orange) WG45/50
- TS-0550-3086 Gen V (5Psi) Inner (Yellow) WG45/50
- TS-0550-3087 Gen V (7Psi) Inner (Green) WG45/50
- TS-0550-3088 Gen V (14Psi) Inner (Blue) WG45/50
- TS-0550-3005 GenV CG Diaphragm Replacement Kit WG45/50
- TS-0550-3014 GenV Actuator Collar Tool Suit WG45/50

Refer to catalogue for further accessories

Install Req.

- Inlet Pipe Suits 50.8/2.00" OD
- Outlet Pipe Suits 50.8/2.00" OD
- Port Tube Min. ID 6mm / 0.236"

Spring Data

Wastegate Size	Spring Pressure			
	3psi	5psi	7psi	14psi
WG45/50	Orange	Yellow	Green	Sky Blue

Boost Pressure	Location	Inner	Inner	Middle	Outer
	Pressure	3psi	5psi	7psi	14psi
3psi		•			
5psi			•		
7psi				•	
10psi		•		•	
12psi			•	•	
14psi					•
17psi		•			•
19psi			•		•
21psi				•	•
24psi		•		•	•
26psi			•	•	•