

# Gen V WG60 Powergate60



The Gen-V WG60 Powergate60 external wastegate is a cost effective, high performing 60mm external wastegate, the largest in the Gen-V range. The Gen-V provides extensive user configurability, world leading extended thermal performance, fatigue resistance and best in class flow performance for optimum control and longevity.

- Liquid cooling provision
- Strap type V-band clamps
- User adjustable actuator position
- Modular actuator design
- Compressed Gas option available

### Mechanical Data

Valve diameter	60mm (2.36in)
Mass	1590g (3.51lbs)
Actuator linearity	1.45% of full lift (BFSL)
Set pressure accuracy	+/- 0.5 psi of base pressure
Safe working pressure max.	220 psi / 1520 kPa / 15 bar
Safe inverted pressure max.	180 psi / 1250 kPa / 12.5 bar
Actuator life	500k cycles @ 180°C (356°F) ambient 650k cycles @ 80°C (176°F) ambient
Actuator/Valve ratio	1.6:1
Max. spring base pressure	26 psi / 180 kPa / 1.8 bar
Min. spring base pressure	3 psi / 21 kPa / 0.2 bar
Port fittings type	Air: 2x 1/8" NPT top chamber Air: 2x 1/8" NPT lower chamber Liquid Cooling: 2x 1/8" NPT

### Thermal Data

Max. thermal stress (non-cooled)*	>30min @ 1250°C (2282°F) EGT continuous
Max. thermal stress (h2O cooled)*	>24hr @ 1250°C (2282°F) EGT continuous
Max. ambient/compartament temp.	260°C / 500°F
Max. actuator temp.	310°C / 590°F

### Material Data

Beryllium (Be)	0%
Main Body	High temp 347 SS
Diaphragm	Proprietary Silicone w/ nomex
Actuator housing	6061 T6 anodised Al.
Valve Guide	Nitronic 60
Valve	EV8 w/ proprietary plating
V-Band	Heat treated 431 SS w/ 18-8 nut
Weld Flanges	304 Stainless Steel
Springs	17-7PH Stainless Steel

### Flow Data

Max. Flow	360.9 CFM/10.22m <sup>3</sup> /min @1psidP
Flow Linearity	-12% of full lift (BFSL)

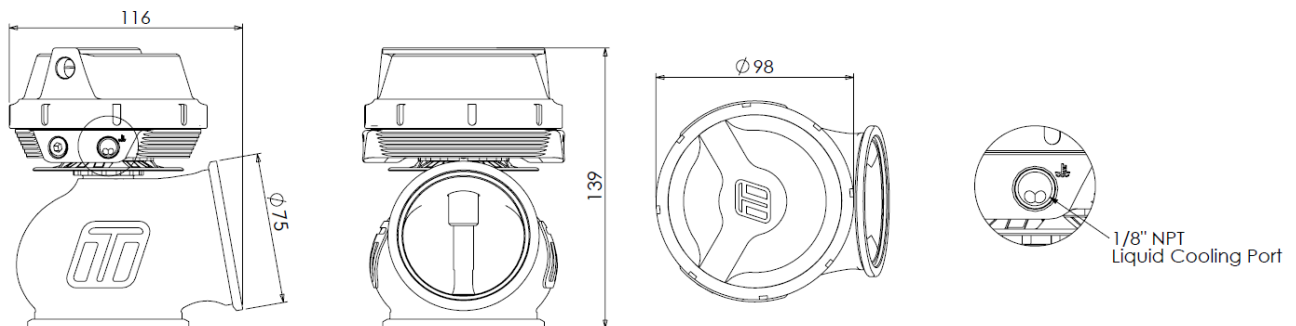
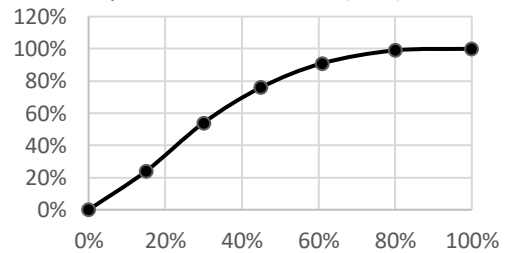

\*Continual source of minimum 1250°C exhaust gas, with no cool down periods for at least 30minutes and no external air cooling on actuator, this is a destructive test that an ICE engine cannot support. Contact tech support for further information.

### Included in the Box

- Wastegate unit (pre-assembled with spring as per order)
- SS316 Valve seat
- Inlet V-Band
- Inlet SS304 weld flange
- Outlet V-Band
- Outlet SS304 weld flange
- Collar tool (master/slave)
- 17-7PH 3, 5, 7, 14 psi spring kit (1x spring installed)
- 4x 1/8" NPT plugs (1x installed) / 2x 1/8" NPT nipples
- Sticker
- Instruction card

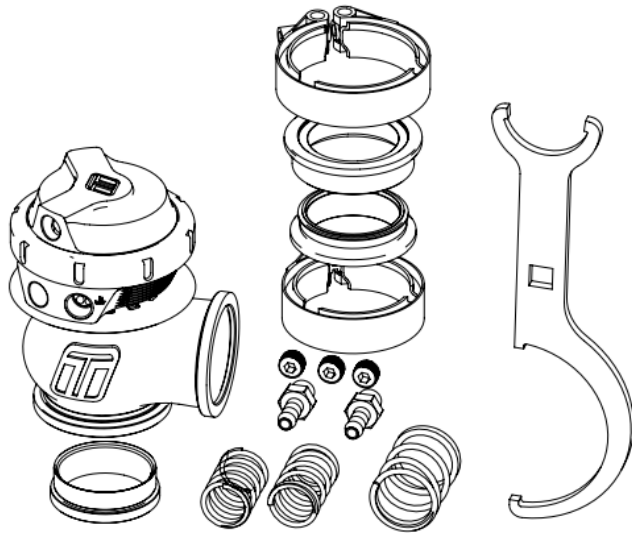

### Order Data

TS-0555-1001	Gen-V WG60 Powergate 60 7psi Blue
TS-0555-1002	Gen-V WG60 Powergate 60 7psi Black
TS-0555-1011	Gen-V WG60 Powergate 60 14psi Blue
TS-0555-1012	Gen-V WG60 Powergate 60 14psi Black
TS-0555-1015	Gen-V WG60 Powergate 60 14psi Sleeper

### Accessories

TS-0555-3001	WG60 Valve seat
TS-0555-3002	WG60 Valve and Guide set
TS-0555-3003	WG60 Inlet V-Band
TS-0555-3004	WG60 Outlet V-Band
TS-0503-3001	WG60 Stainless Inlet Weld Flange
TS-0503-3002	WG60 Stainless Outlet Weld Flange
TS-0503-3007	WG60 Alloy Inlet Weld Flange
TS-0503-3008	WG60 Alloy Outlet Weld Flange
TS-0550-3003	98mm Spring Kit
TS-0550-3026	98mm Sensor Cap Upgrade Black
TS-0550-3027	98mm Sensor Cap Upgrade Blue
TS-0550-3006	98mm Diaphragm Replacement Kit
TS-0550-3015	98mm Actuator Collar Tool

Refer to catalogue for further accessories

### Install Req.

Inlet Pipe	Suits 63.5mm/2.50" OD
Outlet Pipe	Suits 63.5mm/2.50" OD
Port Tube Min. ID	6mm / 0.236"

### Spring Data

Master Collar Size	Spring Pressure			
	3psi	5psi	7psi	14psi
98mm	Raw	Purple	White	Brown

Boost Pressure	Location	Inner	Inner	Middle	Outer
	Pressure	3psi	5psi	7psi	14psi
3psi		•			
5psi			•		
7psi				•	
10psi		•		•	
12psi			•	•	
14psi					•
17psi		•			•
19psi			•		•
21psi				•	•
24psi		•		•	•
26psi			•	•	•

### Configurations Available

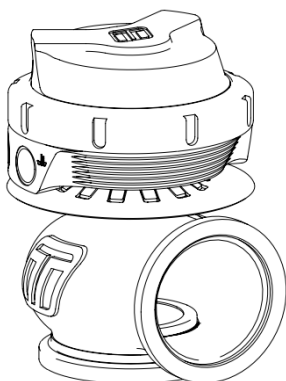

Standard

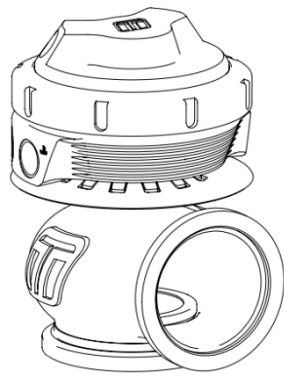

Standard Compressed Gas