

Race Port EM - Blow Off Valve



Engineered to WIN



The RacePort EM is a High Flowing Valve capable of supporting over 2500HP with built in solenoid for advanced control strategies and OE level vehicle integration, where electronic diverter valves are fitted. The RacePort EM (electro-mechanical) is a motorsport quality, high flowing diaphragm operated valve, with modern vehicle technology and motorsport smarts, in mind.

The RacePort EM is a combination of decades of experience with the market leading RacePort 50mm Valve with our Multiple Award Winning and Patented EM (Electro-Mechanical) technology. The RacePort architecture provide market leading flow and reliability with a diaphragm operated valve which has proven to be the most responsive and capable valve of it's kind of the market. Add to this the Multiple Award Winning and patent EM (electro-mechanical) technology which provides seamless electronic integration, you have a motorsport proven solution with genuinely hi end and hi-tech credentials.

Mechanical Data

Valve diameter	52mm (2.04in)
Mass	214g
Safe working pressure max.	220 psi / 1520 kPa / 15 bar
Actuator life	>500 k cycles @ 180°C ambient
Actuator/Valve ratio	1.6:1
Max. spring base pressure	18 inHg (26inHg Combined)
Min. spring base pressure	4 inHg
Port fittings type	Inlet: 2x 1/8" NPT

Material Data

Beryllium (Be)	0%
Main body	6262 T6 anodised Al.
Valve	6262 T6
Inlet	6262 T6
Elastomers	Viton
Diaphragm	Proprietary MILSPEC
Springs	17-7PH

Thermal Data

Min. Operating Temperature	-30°C
Max. Operating Temperature	200°C

Order Data

	<i>Refer to catalogue for accessories</i>
TS-0224-1131	BOV Raceport EM GenV Blue
TS-0224-1132	BOV RacePort EM GenV Black
TS-0224-1133	BOV RacePort EM GenV Purple
TS-0204-1134	BOV RacePort EM GenV Red
TS-0204-1135	BOV RacePort EM GenV Sleeper

Order Data

Refer to catalogue for accessories

TS-0204-1141	BOV RacePort EM Female GenV Blue
TS-0204-1142	BOV RacePort EM Female GenV Black
TS-0204-1143	BOV RacePort EM Female GenV Purple
TS-0204-1144	BOV RacePort EM Female GenV Red
TS-0204-1145	BOV RacePort EM Female GenV Sleeper
TS-0204-1405	BOV RacePort EM Plumback GenV Sleeper
TS-0204-1425	BOV RacePort EM Plumback Female GenV Sleeper
TS-0304-1101	BOV Controller RacePort EM Blue
TS-0304-1102	BOV Controller RacePort EM Black

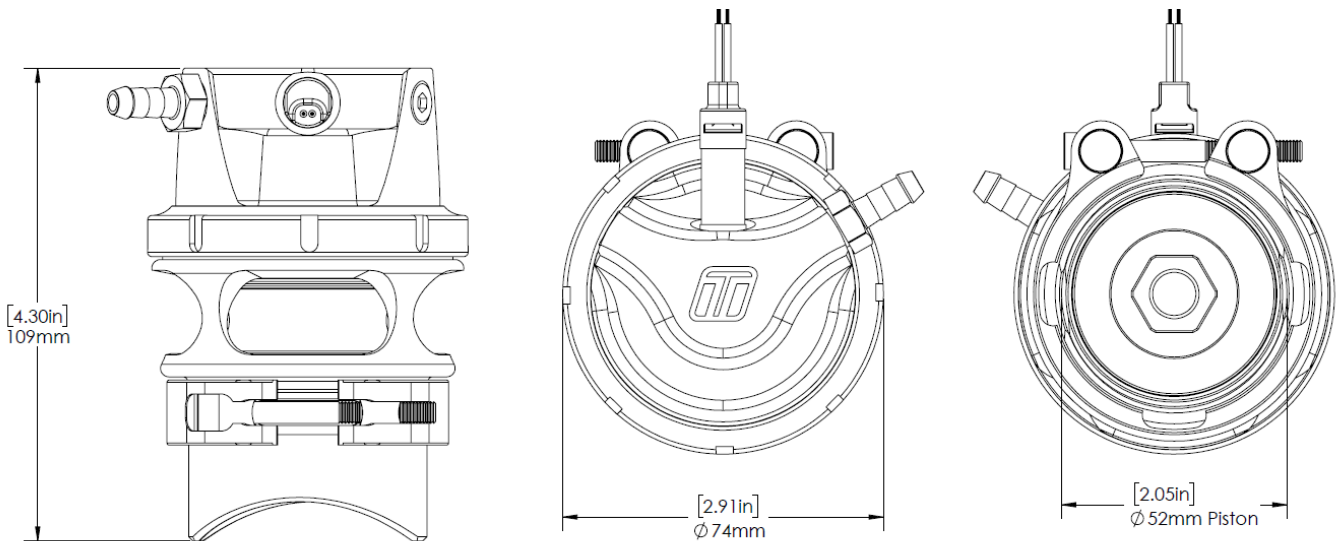

Flow Characteristics

Max Flow

330CFM/9.34m³/min @1psidP *VTA only.

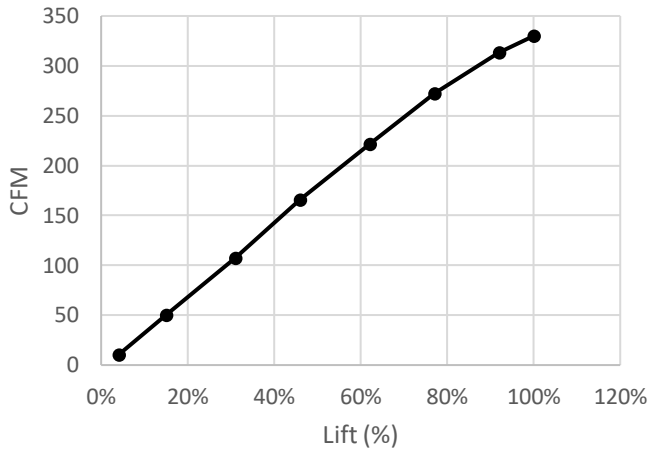

Install Req.

Weld Flange

Suits 76.2mm/3" OD

Included in the Box

- Blow Off Valve
- Inlet V-Band
- Aluminium weld flange
- Sticker
- Instruction card

Spring Chart

	Location	Inner	Inner	Outer	Outer	Outer
	Colour	Pink	Orange	Purple	Green	Blue
	Part #	TS-0203-3002	TS-0204-2105	TS-0204-2104**	TS-0204-3105	TS-0204-3102
	Vacuum	4 InHg	7 InHg	9 InHg	15 InHg	18 InHg
Manifold Vacuum	0-4 InHg	•				
	4-8 InHg		•			
	6-10 InHg			•		
	10-14 InHg	•		•		
	11-15 InHg				•	
	14-18 InHg					•
	15-19 InHg	•			•	
	18-22 InHg	•				•
	19-23 InHg		•		•	
	22-26 InHg		•			•

** Purple TS-0204-2104 only available in the spring kit