

Fuel Filters



Turbosmart Motorsport Proven Billet Inline Fuel Filter with 10-micron washable stainless steel mesh cartridge, Hard Anodized black with Turbosmart Engraving.

Available in -6AN, -8AN, and -10AN solutions, the Turbosmart Billet Fuel Filter provides maximum filtration with minimal restriction, meaning cost-effective insurance for your high-performance and motorsport engine.

It is also a perfect complement to a Turbosmart FPR, Fuel Pressure Regulator Series.



- Suitable for all fuels
- Available in -6, -8 and -10AN
- Available inline Fuel Filter and Billet Fuel Filter
- 10 micron washable stainless steel mesh filter

Mechanical Data

-6AN -8AN -10AN

Safe working pressure max. | 1240 kPag / 180 psig / 12 bar

Thermal Data

Min. Operating Temperature | -30°C
 Max. Operating Temperature | 200°C

Flow Data

10um Filter

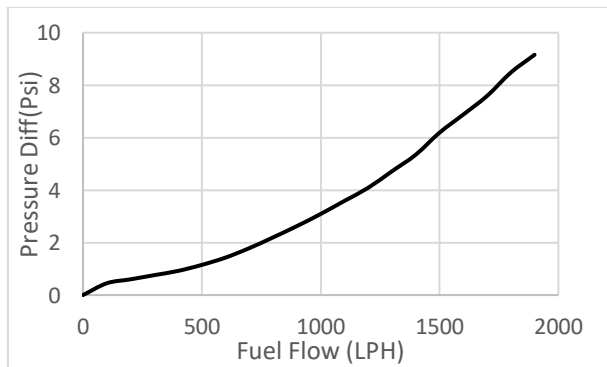

Material Data

Beryllium (Be)	0%
Main body	6262 T6 anodised Al.
Elastomers	Viton
Filter	Stainless Steel Mesh

Order Data

TS-0402-1133	6AN Inline Fuel Filter 10um Black
TS-0402-1134	8AN Inline Fuel Filter 10um Black
TS-0402-1135	10AN Inline Fuel Filter 10um Black
TS-0402-1222	Billet Fuel Filter Canister 10um 6AN Black
TS-0402-1232	Billet Fuel Filter Canister 10um 8AN Black
TS-0402-1242	Billet Fuel Filter Canister 10um 10AN Black

TS-0402-2023	0-100psi Liquid Filled Gauge
TS-0402-3101	10um Fuel Filter 41x74 Replacement
TS-0402-3102	Canister Fuel Filter O-Ring Replacement
TS-0402-3103	Inline Fuel Filter O-ring Replacement
TS-0402-3104	Billet Bracket for 2" Billet Inline Fuel Filter
TS-0402-3105	Billet Bracket for Canister Fuel Filter

*Power calculated is using industry average values, please allow for some safety margin for your application, if in doubt, the next size up regulator is a safe decision.

Billet Fuel Filter

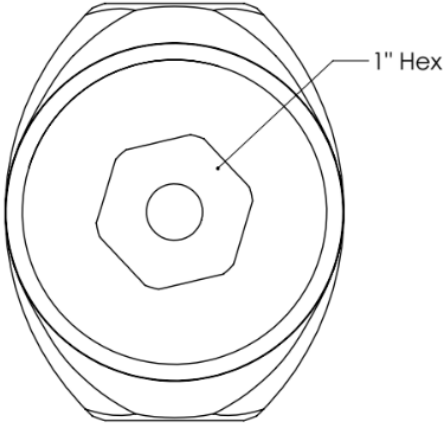
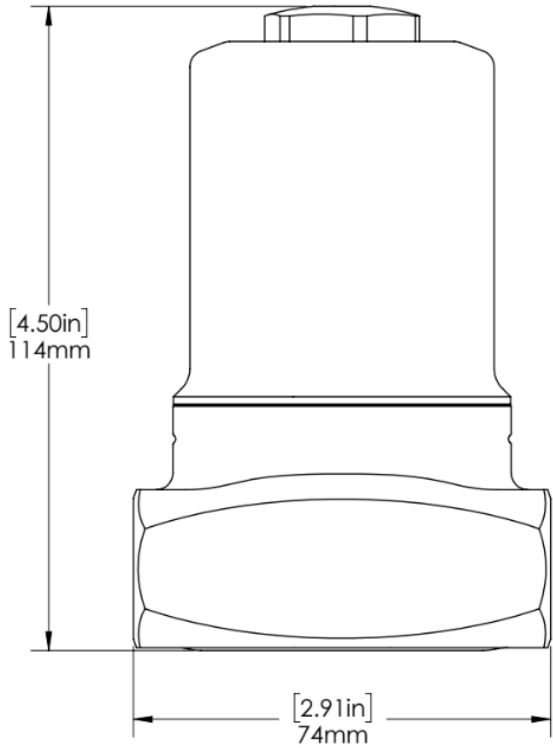
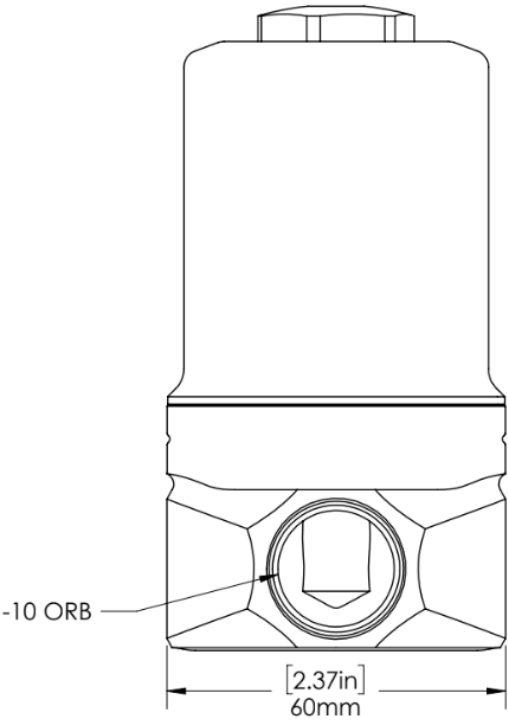

Inline Fuel Filter

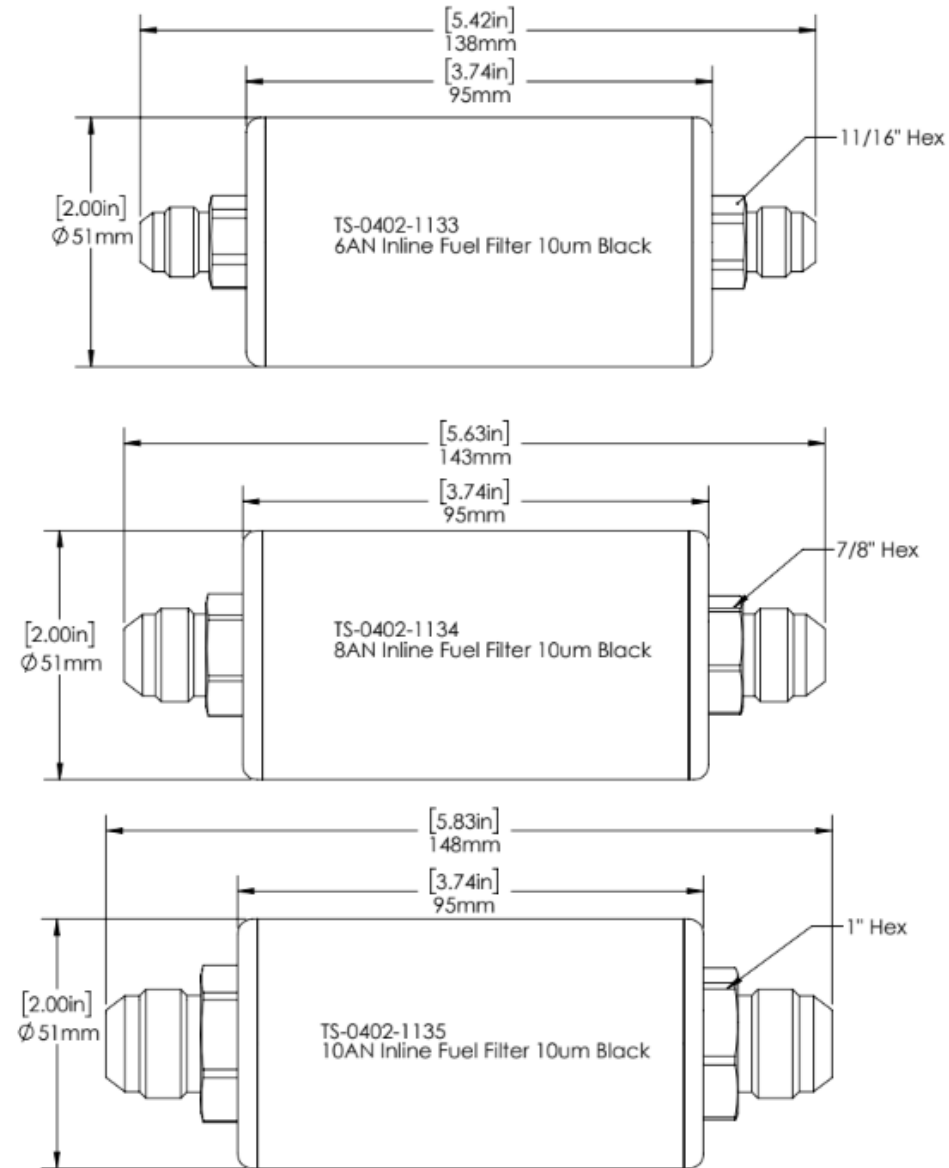

*Power calculated is using industry average values, please allow for some safety margin for your application, if in doubt, the next size up regulator is a safe decision.